

PSC100-056

PENDANT LUMINAIRE - LED 10Wx6



LIGHTING &
EQUIPMENT
PUBLIC COMPANY LIMITED



APPLICATIONS

- * RECREATIONAL CENTERS, HOTELS
- * RESTAURANTS
- * RESIDENTIALS
- * OTHER INDOOR APPLICATIONS WHERE PENDANT LUMINAIRE IS REQUIRED

SPECIFICATION FEATURES

- * LAMP : LED10W x 6
- * SOCKET : N/A
- * SIZE : W1000 x 200 x H1200 mm (w/ sling length)
- * Material : Metal Body with Chinese Grade A crystal
- * WEIGHT : 17 KGS

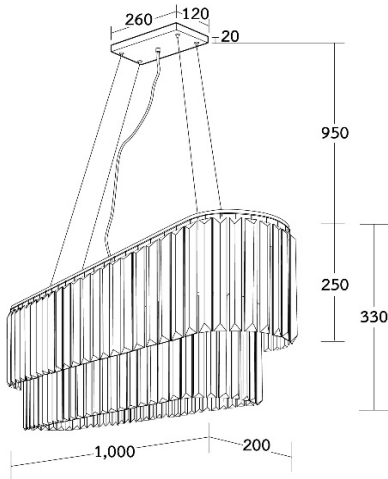

ORDERING DATA

CATALOG NO.	COLOR	LAMP TYPE	REMARKS
PSC100-056/LED60W	CHROME	LED	