

# PSA72-018

PENDANT LUMINAIRE -G9 x 8

**LUMAX**



## APPLICATIONS

- \* RECREATIONAL CENTERS, HOTELS
- \* RESTAURANTS
- \* RESIDENTIALS
- \* OTHER INDOOR APPLICATIONS WHERE PENDANT LUMINAIRE IS REQUIRED

## SPECIFICATION FEATURES

- \* LAMP : Halogen 40W, LED 2W
- \* SOCKET : G9 x 8
- \* SIZE : Dia 720 x H190 mm (w/o Sling Length)
- \* MATERIAL : Aluminum Ring in Gold color

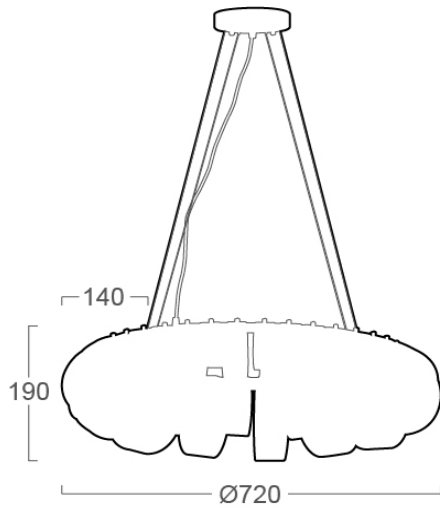

## ORDERING DATA

CATALOG NO.	COLOR	LAMP TYPE	REMARKS
PSA72-018 /G9x8	GOLD	LED 2W	