

PSG55-026

PENDANT LUMINAIRE - E27x3, E14x3



LIGHTING &
EQUIPMENT
PUBLIC COMPANY LIMITED



APPLICATIONS

- * RECREATIONAL CENTERS, HOTELS
- * RESTAURANTS
- * RESIDENTIALS
- * OTHER INDOOR APPLICATIONS WHERE
PENDANT LUMINAIRE IS REQUIRED

SPECIFICATION FEATURES

- * LAMP : LED 3W
- * SOCKET : E27x3, E14x3
- * SIZE : W520 x 600 x H1200 mm (Include Sling Length)
- * Material : Metal Body and Glass

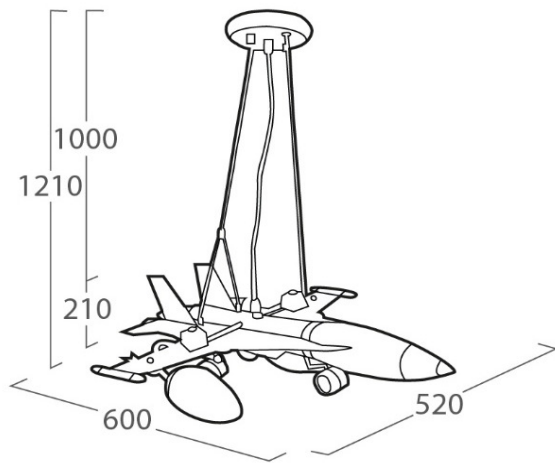

ORDERING DATA

CATALOG NO.	COLOR	LAMP TYPE	REMARKS
PSG55-026 /E27x3, E14x3			

