

PSG67-075

PENDANT LUMINAIRE - E27x5



LIGHTING &
EQUIPMENT
PUBLIC COMPANY LIMITED



APPLICATIONS

- * RECREATIONAL CENTERS, HOTELS
- * RESTAURANTS
- * RESIDENTIALS
- * OTHER INDOOR APPLICATIONS WHERE PENDANT LUMINAIRE IS REQUIRED

SPECIFICATION FEATURES

- * LAMP : LED 3W
- * SOCKET : E27x5
- * SIZE : W700 x 320 x H1300 mm (Include Sling Length)
- * Material : Metal Body and Glass

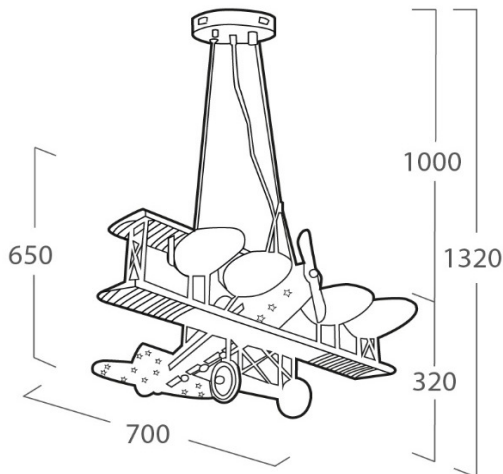

ORDERING DATA

CATALOG NO.	COLOR	LAMP TYPE	REMARKS
PSG67-075 /E27x5	RED		

