

FSS25-021

FLOOR LUMINAIRE /E14x1



**LIGHTING &
EQUIPMENT**
PUBLIC COMPANY LIMITED



APPLICATIONS

- * RECREATIONAL CENTERS, HOTELS
- * RESTAURANTS
- * RESIDENTIALS
- * OTHER INDOOR APPLICATIONS WHERE FLOOR LUMINAIRE IS REQUIRED

SPECIFICATION FEATURES

- * LAMP : LED 3W
- * SOCKET : E14x1
- * SIZE : W460 x 250 x H1400 mm
- * MATERIAL : Metal Body in Black and Red Gold knob
- * Adjustable Up / Down, Left / Right, and Height

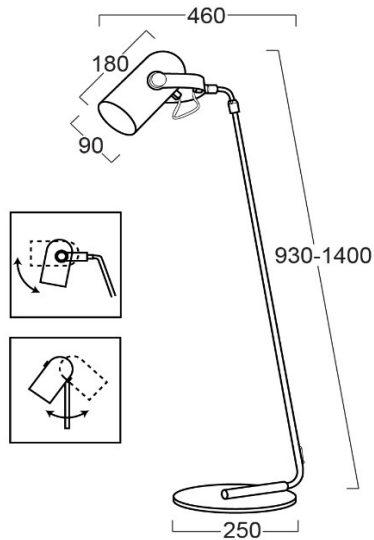

ORDERING DATA

CATALOG NO.	COLOR	LAMP TYPE	REMARKS
FSS25-021 /E14x1	BLACK		