

PSG120-046

PENDANT LUMINAIRE - E27x6

LUMAX



APPLICATIONS

- * RECREATIONAL CENTERS, HOTELS
- * RESTAURANTS
- * RESIDENTIALS
- * OTHER INDOOR APPLICATIONS WHERE PENDANT LUMINAIRE IS REQUIRED

SPECIFICATION FEATURES

- * LAMP : LED 3W
- * SOCKET : E27x6
- * SIZE : W1200 x 185 x H590 mm (w/o Chain Length)
- * MATERIAL : Metal body in Black color, Clear and Faux alabaster glass
- * WEIGHT : 25 Kgs

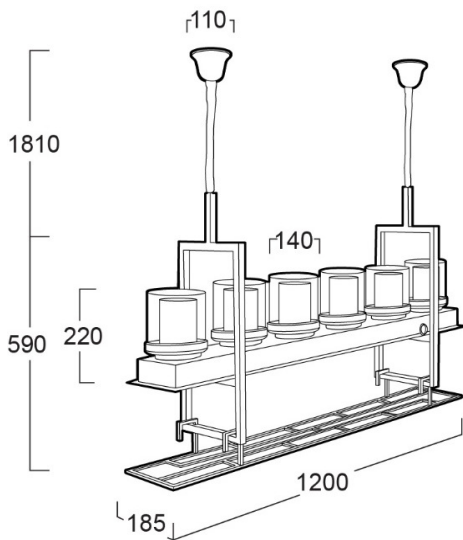

ORDERING DATA

CATALOG NO.	COLOR	LAMP TYPE	REMARKS
PSG120-046 /E27x6	BLACK		