

# PSG88-113

PENDANT LUMINAIRE - E27x12, E14x1

# LUMAX



## APPLICATIONS

- \* RECREATIONAL CENTERS, HOTELS
- \* RESTAURANTS
- \* RESIDENTIALS
- \* OTHER INDOOR APPLICATIONS WHERE PENDANT LUMINAIRE IS REQUIRED

## SPECIFICATION FEATURES

- \* LAMP : LED 6W, 3W
- \* SOCKET : E27x12, E14x1
- \* SIZE : Dia 935 x H800 mm
- \* MATERIAL : Metal body decorate with wood  
White Glass
- \* WEIGHT : 15 Kgs.

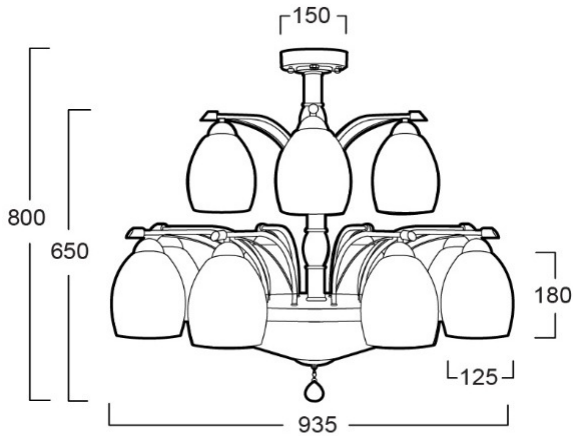

## ORDERING DATA

CATALOG NO.	COLOR	LAMP TYPE	REMARKS
PSG88-113 /E27x12, E14x1			