

PSC43-411

PENDANT LUMINAIRE - E14x11



LIGHTING &
EQUIPMENT
PUBLIC COMPANY LIMITED



APPLICATIONS

- * RECREATIONAL CENTERS, HOTELS
- * RESTAURANTS
- * RESIDENTIALS
- * OTHER INDOOR APPLICATIONS WHERE
PENDANT LUMINAIRE IS REQUIRED

SPECIFICATION FEATURES

- * LAMP : LED 3W
- * SOCKET : E14x11
- * SIZE : dia 460 x 1200 mm (Include Chain Length)
- * MATERIAL : Metal Body and Clear Chinese Crystal
- * NET WEIGHT : 8.50 kgs

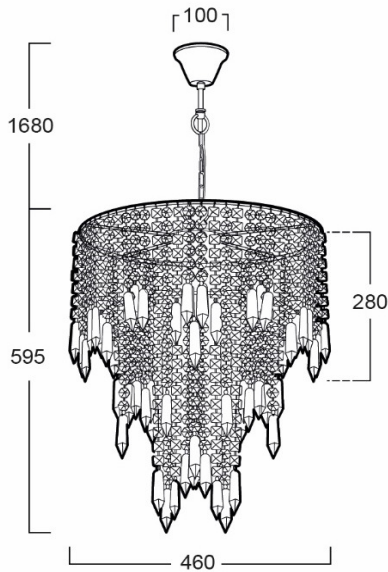

ORDERING DATA

CATALOG NO.	COLOR	LAMP TYPE	REMARKS
PSC43-411/E14x11	CHROME		