

PSS50-143

PENDANT LUMINAIRE - E27x3

LUMAX



APPLICATIONS

- * RECREATIONAL CENTERS, HOTELS
- * RESTAURANTS
- * RESIDENTIALS
- * OTHER INDOOR APPLICATIONS WHERE PENDANT LUMINAIRE IS REQUIRED

SPECIFICATION FEATURES

- * LAMP : LED 5W
- * SOCKET : E27x3
- * SIZE : W500 x 210 x H210 mm (w/o Cable Length)
- * MATERIAL : Metal in Black Color

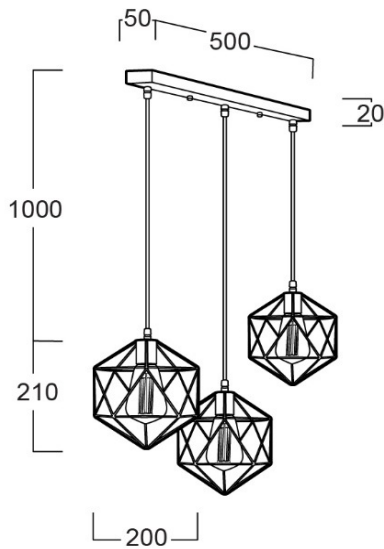

ORDERING DATA

CATALOG NO.	COLOR	LAMP TYPE	REMARKS
PSS50-143 /E27x3	BLACK		