

PWS60-013

PENDANT LUMINAIRE - E27x3

LUMAX



APPLICATIONS

- * RECREATIONAL CENTERS, HOTELS
- * RESTAURANTS
- * RESIDENTIALS
- * OTHER INDOOR APPLICATIONS WHERE PENDANT LUMINAIRE IS REQUIRED

SPECIFICATION FEATURES

- * LAMP : LED 3W
- * SOCKET : E27x3
- * SIZE : W600 x 145 x H1800 mm (Max height)
- * MATERIAL : Wood and Metal Shade
- * WEIGHT : 3.20 Kgs

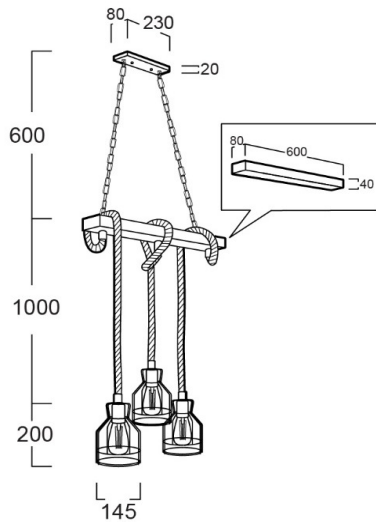

ORDERING DATA

CATALOG NO.	COLOR	LAMP TYPE	REMARKS
PWS60-013 /E27x3	BLACK	LED 3W	