

WSC25-032

WALLMOUNT LUMINAIRE - E14x2



**LIGHTING &
EQUIPMENT**
PUBLIC COMPANY LIMITED



APPLICATIONS

- * RECREATIONAL CENTERS, HOTELS
- * RESTAURANTS
- * RESIDENTIALS
- * OTHER INDOOR APPLICATIONS WHERE WALLMOUNT LUMINAIRE IS REQUIRED

SPECIFICATION FEATURES

- * LAMP : LED 3W
- * SOCKET : E14 x 2
- * SIZE : W240 x 140 x H340 mm
- * MATERIAL : Stainless Steel Body in Silver and Gold, Chinese Grade A Crystal

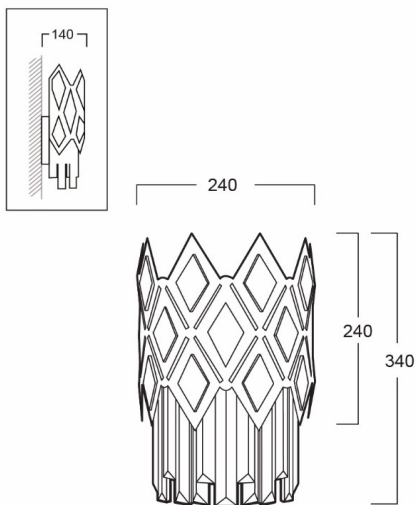

ORDERING DATA

CATALOG NO.	COLOR	LAMP TYPE	REMARKS
WSC25-032 /E14x2	SILVER/GOLD		