

PSG70-186

PENDANT LUMINAIRE - E27x6



LIGHTING &
EQUIPMENT
PUBLIC COMPANY LIMITED



APPLICATIONS

- * RECREATIONAL CENTERS, HOTELS
- * RESTAURANTS
- * RESIDENTIALS
- * OTHER INDOOR APPLICATIONS WHERE PENDANT LUMINAIRE IS REQUIRED

SPECIFICATION FEATURES

- * LAMP : LED 3W
- * SOCKET : E27x6
- * SIZE : Dia 600 x 600 mm (w/o Chain Length)
- * MATERIAL : Metal Body in Matt Black, and Wood Color Glass Shade
- * WEIGHT : 10.50 Kgs

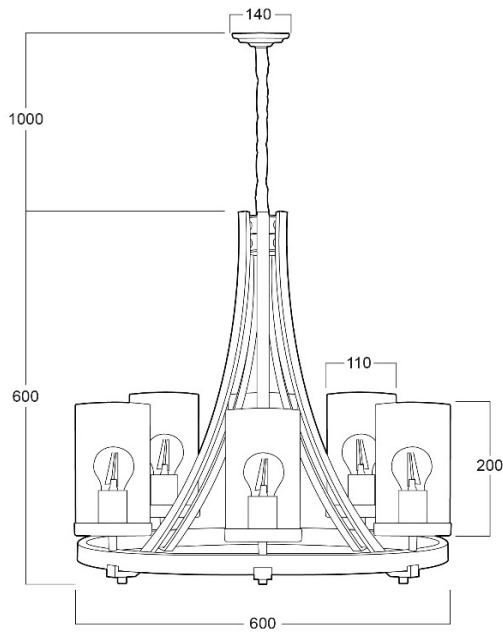

ORDERING DATA

CATALOG NO.	COLOR	LAMP TYPE	REMARKS
PSG70-186 /E27x6	Black, Brown		