

WSG15-111

WALLMOUNT LUMINAIRE - E27x1



LIGHTING &
EQUIPMENT
PUBLIC COMPANY LIMITED



APPLICATIONS

- * RECREATIONAL CENTERS, HOTELS
- * RESTAURANTS
- * RESIDENTIALS
- * OTHER INDOOR APPLICATIONS WHERE WALLMOUNT LUMINAIRE IS REQUIRED

SPECIFICATION FEATURES

- * LAMP : LED 3W
- * SOCKET : E27 x 1
- * SIZE : W150 x 160 x H330 mm
- * MATERIAL : Metal Body in Matt Black, and Wood Color Glass Shade
- * WEIGHT : 1.80 Kgs

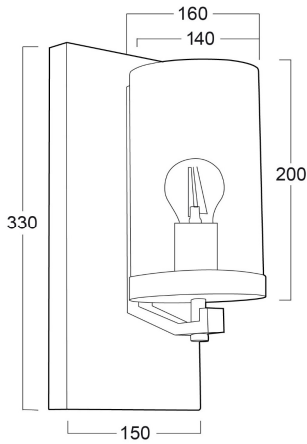

ORDERING DATA

CATALOG NO.	COLOR	LAMP TYPE	REMARKS
WSG15-111 /E27x1	Black/Brown		