

PSS60-116

PENDANT LUMINAIRE - E27x6

LUMAX



APPLICATIONS

- * RECREATIONAL CENTERS, HOTELS
- * RESTAURANTS
- * RESIDENTIALS
- * OTHER INDOOR APPLICATIONS WHERE PENDANT LUMINAIRE IS REQUIRED

SPECIFICATION FEATURES

- * LAMP : LED 6W
- * SOCKET : E27x6
- * SIZE : dia600 x H580 mm (w/o Cable Length)
- * MATERIAL : Metal in Black Color , Rope
- * WEIGHT : 3.70 Kgs

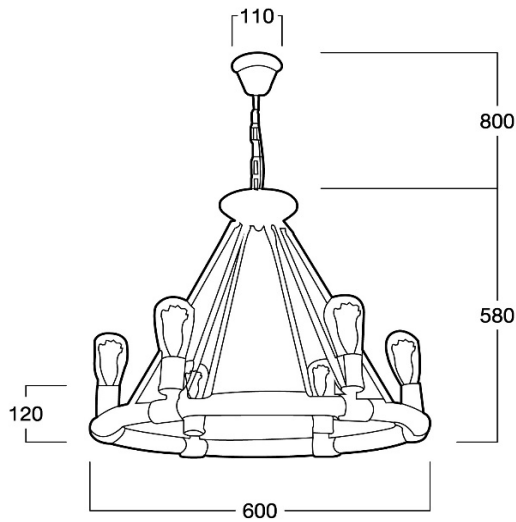

ORDERING DATA

CATALOG NO.	COLOR	LAMP TYPE	REMARKS
PSS60-116 /E27x6	BLACK	LED 6W	