

PSS100-058

PENDANT LUMINAIRE - E27x8

LUMAX



APPLICATIONS

- * RECREATIONAL CENTERS, HOTELS
- * RESTAURANTS
- * RESIDENTIALS
- * OTHER INDOOR APPLICATIONS WHERE PENDANT LUMINAIRE IS REQUIRED

SPECIFICATION FEATURES

- * LAMP : LED 6W
- * SOCKET : E27x8
- * SIZE : Dia 950 x H800 mm
- * MATERIAL : Metal ain Black Color
- * Adjustable Arm angle
- * WEIGHT : 2.0 Kgs

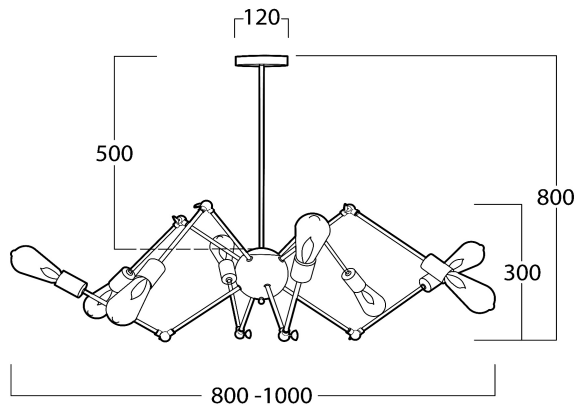

ORDERING DATA

CATALOG NO.	COLOR	LAMP TYPE	REMARKS
PSS100-058 /E27x8	Black		