

# PSG60-2810

PENDANT LUMINAIRE - G9x10



LIGHTING &  
EQUIPMENT  
PUBLIC COMPANY LIMITED



## APPLICATIONS

- \* RECREATIONAL CENTERS, HOTELS
- \* RESTAURANTS
- \* RESIDENTIALS
- \* OTHER INDOOR APPLICATIONS WHERE  
PENDANT LUMINAIRE IS REQUIRED

## SPECIFICATION FEATURES

- \* LAMP : LED 2W
- \* SOCKET : G9x10
- \* SIZE : dia 560 xH500 mm (w/o Chain Length)
- \* MATERIAL : Metal Body and Glass Rod
- \* WEIGHT : 21 Kgs

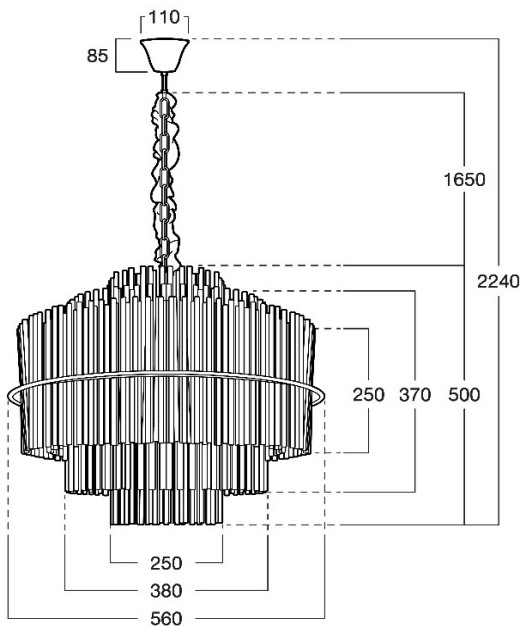

## ORDERING DATA

CATALOG NO.	COLOR	LAMP TYPE	REMARKS
PSG60-2810/G9x10	GOLD		