

PSC60-1616

PENDANT LUMINAIRE - E14x16



LIGHTING &
EQUIPMENT
PUBLIC COMPANY LIMITED



APPLICATIONS

- * RECREATIONAL CENTERS, HOTELS
- * RESTAURANTS
- * RESIDENTIALS
- * OTHER INDOOR APPLICATIONS WHERE PENDANT LUMINAIRE IS REQUIRED

SPECIFICATION FEATURES

- * LAMP : LED 3W
- * SOCKET : E14x16
- * SIZE : dia 560 x 400 mm (W/O Chain and Cable Length)
- * MATERIAL : Metal Body in Gold color
Chinese Grade A Clear Crystal
- * NET WEIGHT : 16 kgs

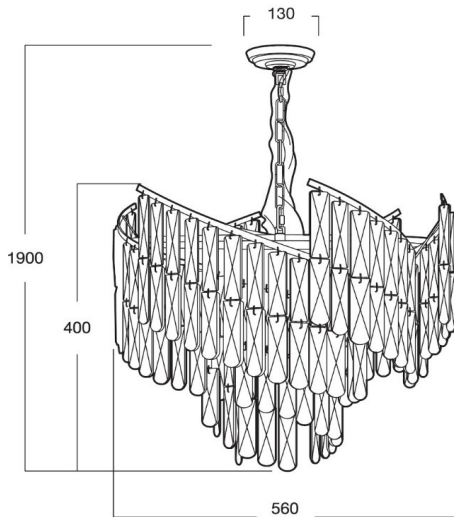

ORDERING DATA

CATALOG NO.	COLOR	LAMP TYPE	REMARKS
PSC60-1616 /E14x16	GOLD		