

PSW35-041

PENDANT LUMINAIRE -E27x1

LUMAX



APPLICATIONS

- * RECREATIONAL CENTERS, HOTELS
- * RESTAURANTS
- * RESIDENTIALS
- * OTHER INDOOR APPLICATIONS WHERE PENDANT LUMINAIRE IS REQUIRED

SPECIFICATION FEATURES

- * LAMP : LED 6W
- * SOCKET : E27x1
- * SIZE : dia 350 x H290 mm (w/o Cable Length)
- * MATERIAL : Metal Plate and Rattan and Plastic shade
- * WEIGHT : 1.20 Kgs

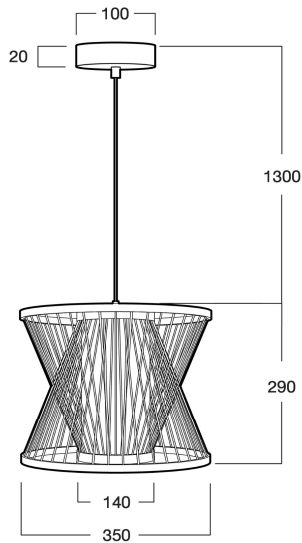

ORDERING DATA

CATALOG NO.	COLOR	LAMP TYPE	REMARKS
PSW35-041 /E27x1	BEIGE		