

PSC80-1713

PENDANT LUMINAIRE - LED150W



LIGHTING & EQUIPMENT
PUBLIC COMPANY LIMITED



APPLICATIONS

- * RECREATIONAL CENTERS, HOTELS
- * RESTAURANTS
- * RESIDENTIALS
- * OTHER INDOOR APPLICATIONS WHERE PENDANT LUMINAIRE IS REQUIRED

SPECIFICATION FEATURES

- * LAMP : LED150W 3000K
- * SOCKET : N/A
- * SIZE : Dia 800 x 2250 mm
- * Material : Stainless Gold frame, K9 crystal
- * WEIGHT: 35 kgs

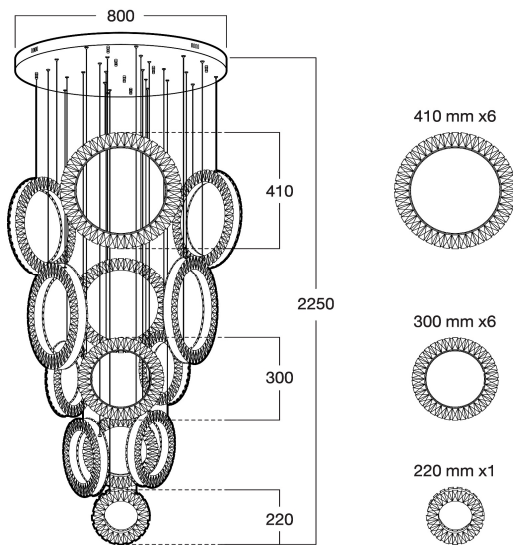

ORDERING DATA

CATALOG NO.	COLOR	LAMP TYPE	REMARKS
PSC80-1713/LED150W	GOLD		