

# PSS24-081/BK/R

PENDANT LUMINAIRE - E27x1



LIGHTING &  
EQUIPMENT  
PUBLIC COMPANY LIMITED



## APPLICATIONS

- \* RECREATIONAL CENTERS, HOTELS
- \* RESTAURANTS
- \* RESIDENTIALS
- \* OTHER INDOOR APPLICATIONS WHERE PENDANT LUMINAIRE IS REQUIRED

## SPECIFICATION FEATURES

- \* LAMP : LED 9W
- \* SOCKET : E27 x 1
- \* SIZE : dia 240 x H1200 mm (Include Cable)
- \* Material : Metal with Outside Black Color and Inside Red Color

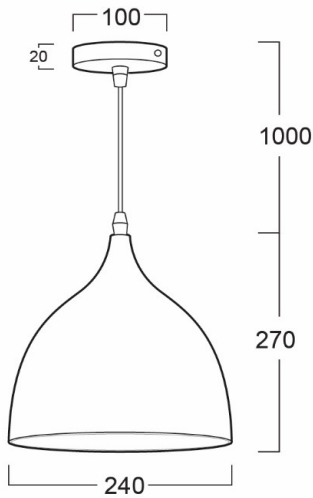

## ORDERING DATA

| CATALOG NO.          | COLOR     | LAMP TYPE | REMARKS |
|----------------------|-----------|-----------|---------|
| PSS24-081/BK/R/E27x1 | BLACK/RED | LED 9W    |         |