

# PSS28-051/SQ

PENDANT LUMINAIRE - E27x1



**LIGHTING &  
EQUIPMENT**  
PUBLIC COMPANY LIMITED



## APPLICATIONS

- \* RECREATIONAL CENTERS, HOTELS
- \* RESTAURANTS
- \* RESIDENTIALS
- \* OTHER INDOOR APPLICATIONS WHERE  
PENDANT LUMINAIRE IS REQUIRED

## SPECIFICATION FEATURES

- \* LAMP : LED 9W
- \* SOCKET : E27x1
- \* SIZE : W280 x 100 x H280 mm (w/o Cable length)
- \* Material : Painted Metal in Black Color

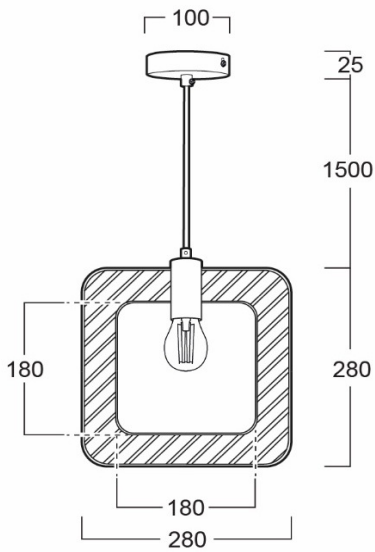

## ORDERING DATA

CATALOG NO.	COLOR	LAMP TYPE	REMARKS
PSS28-051/SQ/E27x1	BLACK		