

# LED Surface Downlight



TIS **SAM97**

## Application

Surface downlight is designed to use for office buildings, shopping centers, convenience stores, modern trade stores, discount stores, hotels, restaurants, residences, recreational centers, museums, etc.

## Specification

<b>Housing</b>	Die-cast aluminium lamp cover and extruded aluminium
<b>Finishing</b>	Powder Coated in white / black
<b>Mounting Surface</b>	Surface
<b>Power</b>	1x4-8W (1 lamp) 2x8-16W (2 lamps)
<b>Light Source</b>	LED-MR16
<b>Lamp Holder</b>	GX5.3
<b>Colour Temperature</b>	2700 - 4000K
<b>Lamp Output</b>	6W : 2700/3000/4000/6500K : 550 lm 7W : 2700K : 550 lm 7W : 3000K : 600 lm
<b>Control Gear</b>	Built-in electronic transformer
<b>Power Supply</b>	220-240VAC, 50Hz
<b>Power Factor</b>	>0.9
<b>Insulation Class</b>	I
<b>IP Rating</b>	20
<b>LED Lifetime</b>	6W : 15,000 hrs. 7W : 25,000 hrs
<b>Equivalent</b>	MR16 35 - 50W

## Ordering Data

Model	Watt
SAM97/WH-1xXXLED-MR16	4-8W
SAM97/WH-2xXXLED-MR16	8-16W

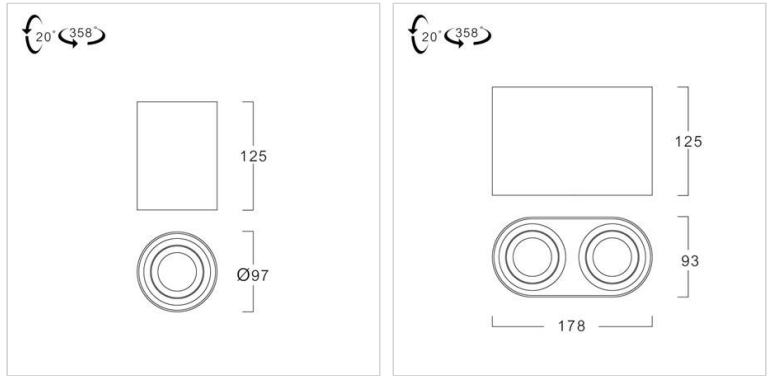

## Related Products

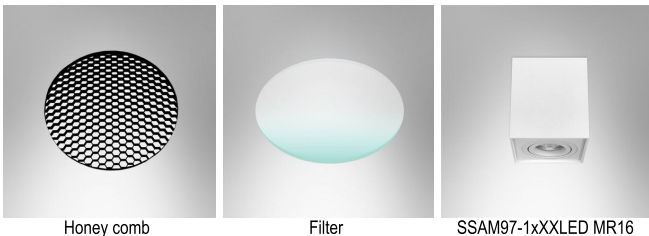

Honey comb

Filter

SSAM97-1xXXLED MR16

