

LED Clean Room



TIS LRCRM600/RO

Application

Clean room is designed for unique application which is require limitation of dust such as food processing areas, control rooms, etc.

Specification

Housing	Die-formed cold roll steel Service method : Rear opening Sealing : Triple gasketing system
Description	Can use for cleanroom class 10,000 or higher
Finishing	Powder coated in white
Diffuser	Prismatic (Opal, stipple, clear are available as option)
Mounting	Recessed
Power	2S:16-20W (2 lamps) 3S:24-30W (3 lamps) 2L:28-40W (2 lamps) 3L:42-60W (3 lamps)
Light Source	LED-T8
Lamp Holder	G13
Colour Temperature	3000/4000/6500K
Lamp Output	2S:L&E : 2x8/9W:2x1050 lm 3S:L&E : 3x8/9W:3x1050 lm 2L:L&E : 2x14/16/18W:2x2100 lm 3L:L&E : 3x14/16/18W:3x2100 lm
Luminaire Output	2S:16/18W : 1585 lm 3S:24/27W : 2380 lm 2L:28/32/36W : 3175 lm 3L:42/48/54W : 4760 lm
Power Supply	220VAC 50Hz
Insulation Class	I
IP Rating	50
LED Lifetime	L&E:25,000/50,000 hrs.
Equivalent	16-20W:T5 2x14W/T8 2X18W 24-30W:T5 3x14W/T8 3x18W 28-40W:T5 2X28W/T8 2X36W 42-60W:T5 3x28W/T8 3x36W

Ordering Data

Model	Watt
LRCRM600/RO/2S/OT-XXLED-T8	16-20W
LRCRM600/RO/3S/OT-XXLED-T8	24-30W
LRCRM600/RO/2L/OT-XXLED-T8	28-40W
LRCRM600/RO/3L/OT-XXLED-T8	42-60W

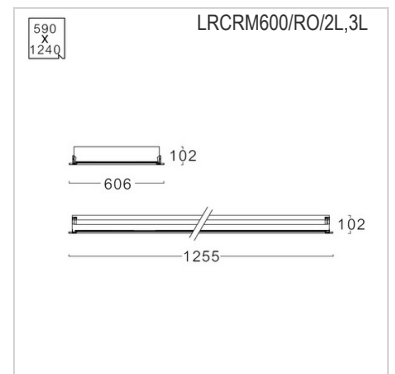
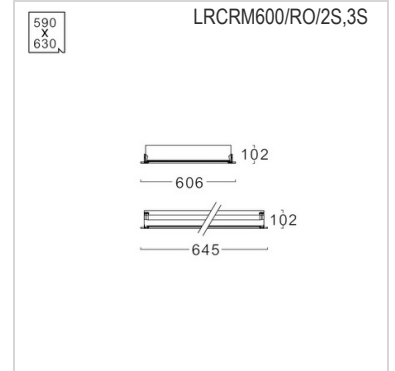

Related Products



LED-T8