

LED Lamp

 TIS ELED-T8/LIGHT SENSOR

Application

This LED lamp is designed to replace conventional lamp which is safe cost and save energy depending on each lamp types. There is no UV, long lifetime, etc.

Specification

Housing	Frosted glass tube is excellent designed to protect injury cause of electric shock
Description	Energy saving up to 55% No UV and IR, non-dimmable On/Off with light sensor Off when ambient illumination >50 lux Can be used with existing magnetic ballast but must be taken out starter Can not be used with dimmer
Power Source	9/18W LED-Module
Lamp Holder	G13
Lamp Colour	6500K
Lamp Output	9W: 900lm 18W: 1800lm
Beam Angle	230 degree
Control Gear	Built-in driver
Power Supply	220VAC 50Hz
LED Lifetime	25,000 hrs
Equivalent	9W: T5 1x14W/T8 1x18W 18W: T5 1x28W/T8 1x36W

Ordering Data

Model	Watt
LUMAX#Ecosave Plus T8-900LM/765/9W/OT/LIGHT SENSOR	9W
LUMAX#Ecosave Plus T8-1800LM/765/18W/OT/LIGHT SENS	18W

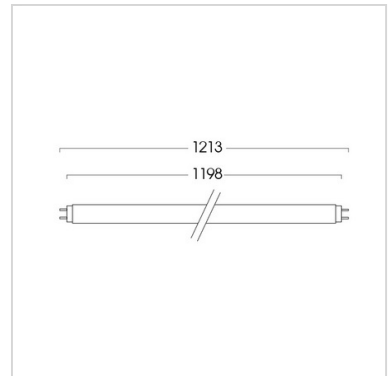
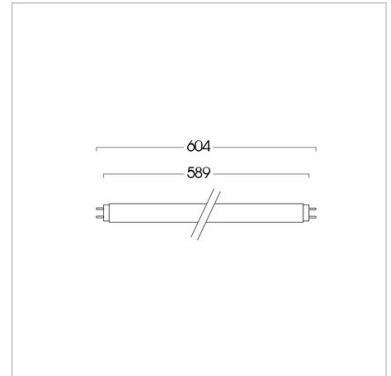

Related Products

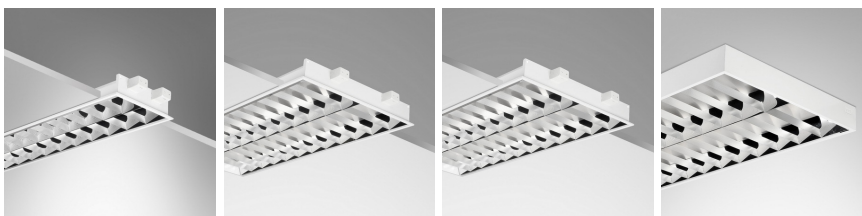

Recessed Luminaire

Recessed Luminaire