

LED Accent SLA309-1C

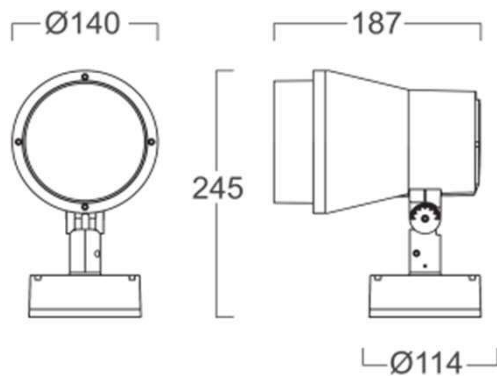

LIGHTING & EQUIPMENT
PUBLIC COMPANY LIMITED



SLA309-1C, the accent luminaire with a high efficiency Power LED Lightsource, designed for saturated color effects. Not only the higher brightness than other LED product in the market, but also **SLA309-1C** consumes less power than other lightsource, only 27 watt. Featuring IP65 weather protection rating and 50,000 hours lifetime of Power LED.

Specification

Housing	High pressure die-cast Aluminium Housing with outrigger arm in extruded aluminium, Adjustable and durable swivel unit	
IP rating	65	
Dimension	140 x 245 mm	
No. of LEDs	3W x 9 High Power LEDs	
Color Range	2700K, 3000K, 4000K, 6500K, RED, GREEN, BLUE	
Beam Angle	10°, 25°, 45°	
LED Lifetime	50,000 hrs. (L70)	
Operating Voltage	24 Vdc	
Power consumption	27 W	
Lumen Output	2700K	820 lm
	3000K	890 lm
	4000K	935 lm
	6500K	988 lm
Control & Interface	Dimming by 0-10Vd or DMX system, Addition dimmable driver	

Optional : Can be chosen aluminium glare shield cap.



For further information, please contact :
Lighting & Equipment Public Co., Ltd.
16th-17th Flr. Gypsum Metropolitan Tower,
539/2 Sri-Ayudthaya Rd., Ratchatevee, Bangkok 10400, Thailand